

#### 4、USM50 超声电机

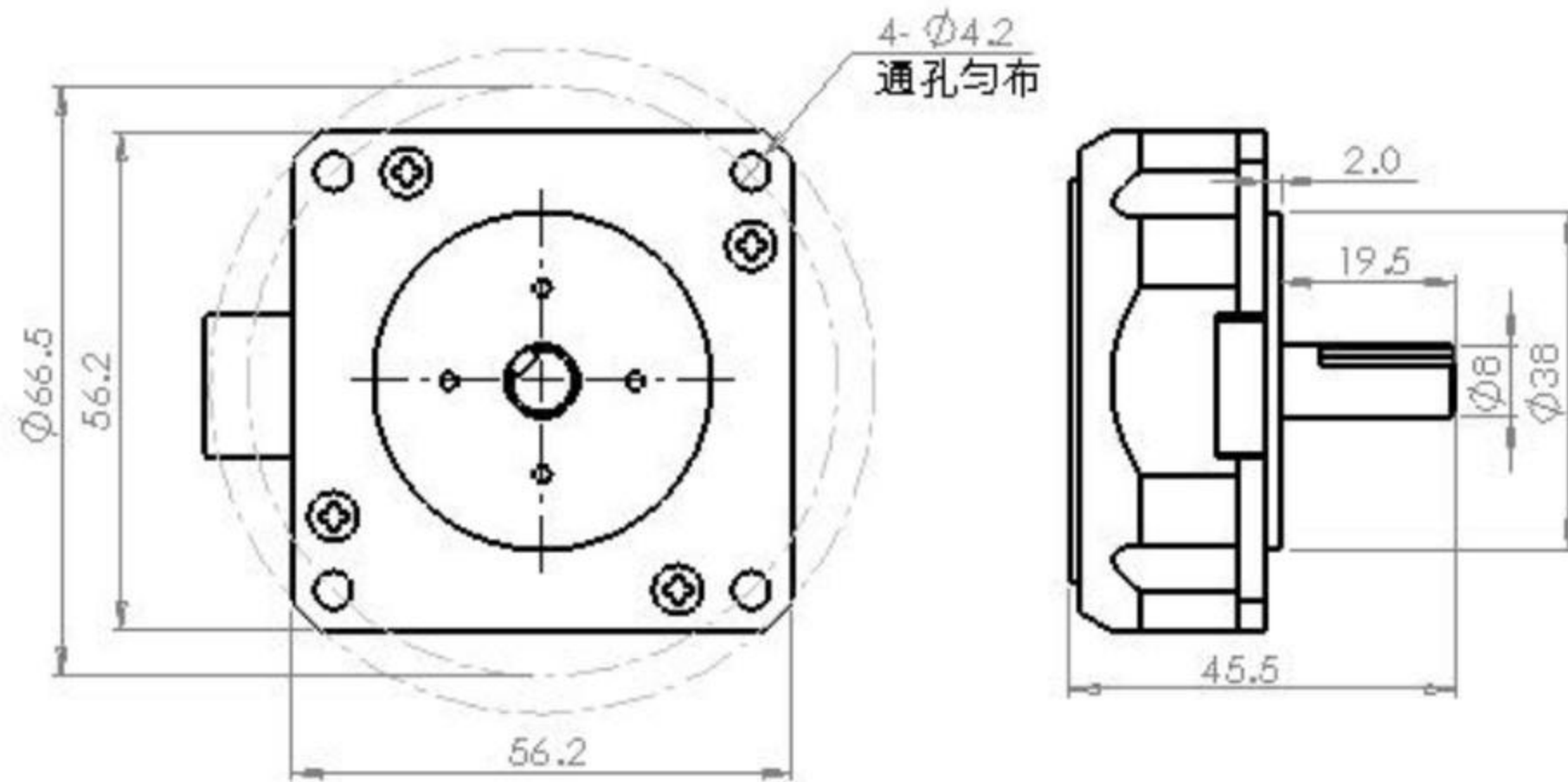

转速-转矩曲线图 Rotation rate-torque cure diagram

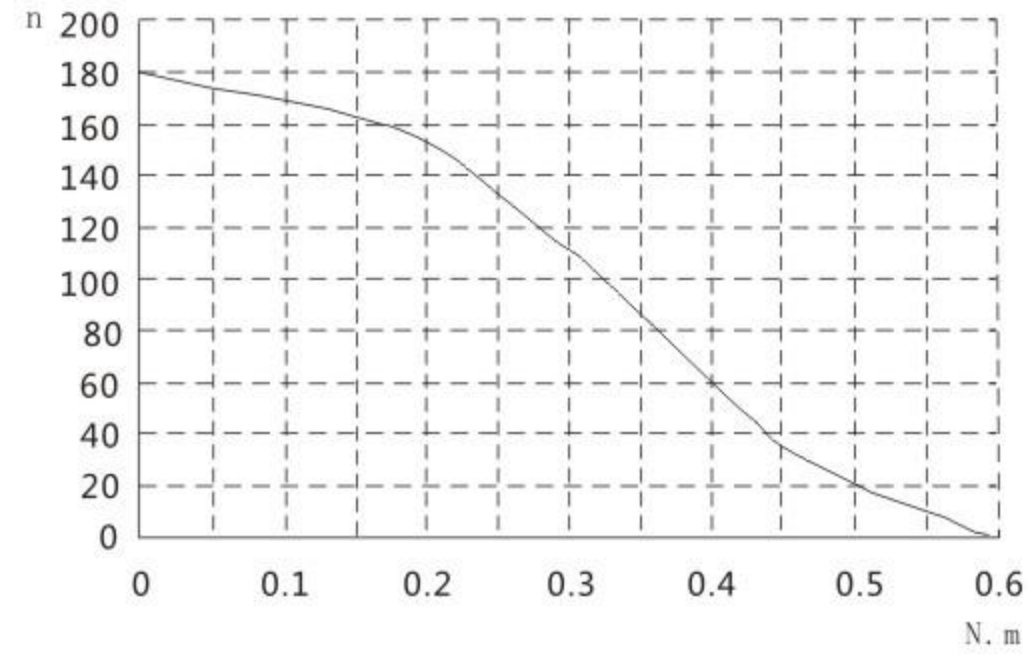

#### USM50 超声电机技术参数 | USM50 technical parameters

Size	外形	56.2X56.2X26 mm
Diameter of axle	轴径	Φ8
Weight	重量	189 g
Working Frequency	工作频率	38±2 KHz
Working Voltage	工作电压	140 Vrms
Output power	输出功率	3.5 w
Rated speed	额定转速	110 rpm
Rated torque	额定力矩	0.3 N.m
Holding torque	保持力矩	≥0.6 N.m
Max torque	最大力矩	0.6 N.m
Max speed	最高转速	180 rpm
Start response time	启动响应时间	≤ 4 ms
Stop response time	停止响应时间	≤ 2 ms
Temperature rising	工作温升	≤ 15 °C
Environmental temperature	环境温度	-25 °C--55 °C
Storage temperature	储存温度	-40 °C--100 °C
Accumulative	累计寿命	1500 h
Noise	噪音	≤ 45 dB

#### USM50 超声电机控制器参数 | The control device of USM50

Size	外形	100X65X35 mm
Supply voltage	电源电压	24 v
Working current	工作电流	≤ 1.0 A
Working frequency	工作频率	38±5 KHz
Output waveform	输出波形	类似正弦波
Speed adjustment rang	速度调节范围	5~150 rpm
Speed adjustment way	速度调节方式	频率调节
The way of open and stop	启停控制方式	高低电平
Environmental temperature	环境温度	-25 °C--55 °C
Storage temperature	储存温度	-40 °C--100 °C
Weight	重量	253 g